

1clic 2go pure installation



Important notice: prior to and during the flooring installation, please read the installation instructions completely! The flooring procedure is accomplished according to ATV DIN 18365.

Follow these instructions precisely, in order to retain full rights to claims under the guarantee.

Various possibilities for installation are offered depending on the surface area to be used:

1. Quick and easy installation without glue

2. Installation with Clickguard™: for the installation of laminate flooring in commercially-utilized rooms, a sealing procedure must be carried out [11]. Clickguard™ protects the flooring from the top down for the long-term against the effects of moisture. The floor lamination can be removed later and newly installed. When using Clickguard™, please follow the installation instructions. In the event that a sealant is to be used, sufficient quantities of Clickguard™ are to be applied to the tongue-spring side [11] (1 layer lengthwise and 1 layer for the width). The excess Clickguard™ should be scraped off from the surface with a plastic spatula after max. 15 – 20 minutes. Eventual remnants (residue) can be removed with household solvent cleanser.

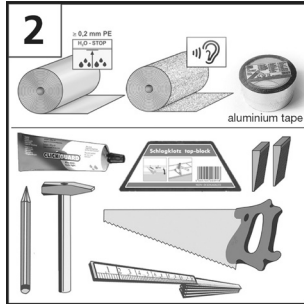
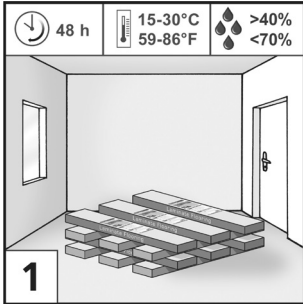

Preparation: Please store the packets 48 hours prior to installation under the same climatic conditions (temperature and moisture) as the actual installation process [1]. Important pre-condition for proper fitting and long-term durability of the laminated flooring is a room temperature of 15 – 30°C / 59 – 86°F and a relative humidity of around 40 – 70%.

Necessary Materials and Tools: polyethylene-foil, aluminium jointing tape, separation shims, footfall sound insulation, saw, pencil, folding ruler [2].
If necessary: spacers, hammer, Clickguard™ joint sealant.

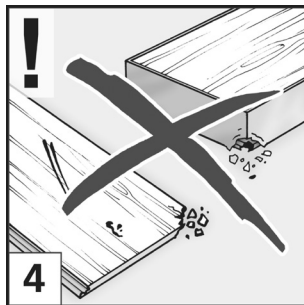
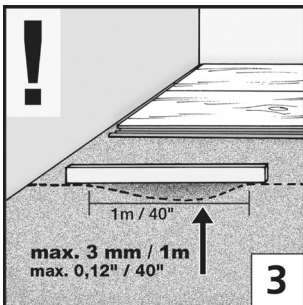

The sub-surface that the laminate flooring will be applied to must be furnished in such a way that the laminate flooring can be installed as required by the manufacturer's instructions. Appropriate sub-surfaces are, among others, mineral sub-surfaces (such as floor screed, concrete, asphalt), particle-board sheets and timber floor boards. The sub-surface must be absolutely even, dry, clean and stable. Floor irregularities measuring more than 3 mm per 1 meter / 0.12" per 39.37" length must be evened out by a professional (according to DIN 18202) [3]. The evenness of the sub-surface can be best ascertained by means of a straightedge or a spirit level. When installing onto a mineral sub-surface such as concrete, cement-screed, anhydrite-screed or flagstone (among others), a moisture measurement must first be carried out. The following remnant-moisture levels in the screed may not be exceeded, prior to installation:

Cement-screed:	without underfloor heating	< 2,0% CM
Calcium sulfate screed:	without underfloor heating	< 0,5% CM

No offsets, steps or similar unevenness must be present. Construction rubble such as plaster residue or similar must be removed completely. Cracks in the ground must also be considered as critical. In order to assert full claims for damages, the provisions of ATV DIN 18365 and § 4 para. 3 VOB/B must be observed.

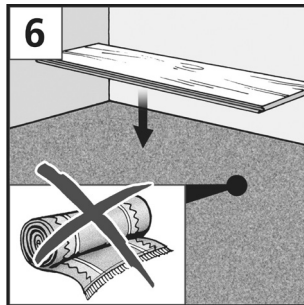
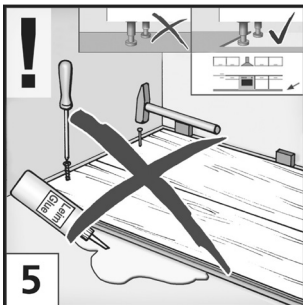

Check the panels under good lighting conditions for irregularities. Boards with visible defects outside the applicable tolerances, such as deviations in height, gloss, dimensional and color, must be sorted out and replaced free-of-charge [4]. For already-fitted or previously-worked panels, a reclamation claim from you is no longer possible.

Lamination flooring is installed under "floating" conditions and may not be glued, screwed, nailed, or in any other fashion fixed to the floor!

The placement of very heavy objects, such as fitted kitchens, also has a fixing effect. It is recommended to install fitted kitchens and cupboards before laying and to lay laminate floor only up to behind the plinth panel. In the event of failure to comply with these requirements any claims for damages shall be excluded [5].

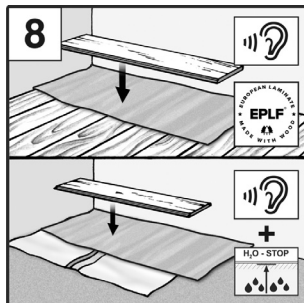
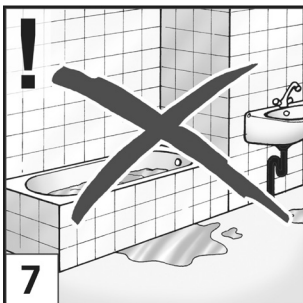

Carpet flooring must be removed and is not suitable as a sub-surface for the lamination flooring. Due to the carpeting lying under the lamination, problems arise when the laminate is walked on in that a spring-motion occurs and considerable pressure is exerted on the lamination edges. This destroys the groove-tongue connection and leads to the formation of a gap. The carpet flooring must also be removed for hygienic reasons. Resulting moisture may result in mold and bacteria forming [6].

Please note that this laminate flooring is not suitable for wet-rooms (e.g. bath or sauna) [7].

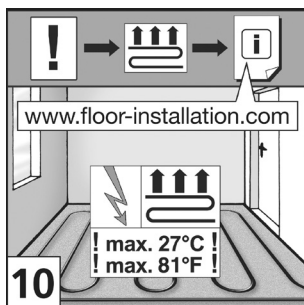
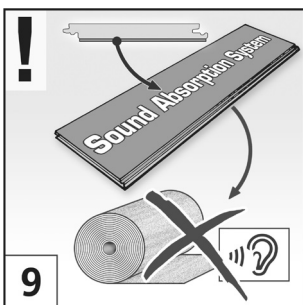

In the case of a wooden sub-surface such as installed sheets or floorboards, no polyethylene foil may be installed. Prior to installing the laminate flooring on a mineral-based sub-surface, (concrete, screed, etc.) it is crucial that a suitable vapour barrier sheet (PE-foil) is put down (with 1 - 2 centimetre / 0.40" - 0.80" 90° edging at the sides- like a shallow tub) as a protection against moisture. The tile channels are installed next to one another and overlapping each other by about 50 mm / 2", and fixed with special aluminium jointing tape. On all substrates, a system-based insulation underlay is recommended to improve sound minimization. The insulation underlay is installed edge to edge, i.e. is not overlapping [8]. Make sure that the insulation underlay joints are not directly under the laminate joints. If the laminate flooring already has an integrated insulation inlay, no additional insulation material is necessary [9].

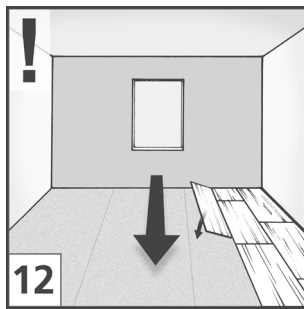
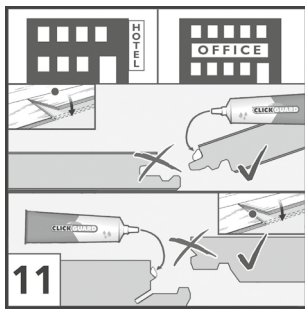

The use of underfloor heating (hot water / electric) is only possible if expertly laid and provided that the heating operates properly [10]. The supply and installation of the underfloor heating system must be state of the art and it must be commissioned by a specialist company in accordance with the relevant heating criteria. Accordingly, a signed heating-up and cooling-down protocol must be in place. Underfloor heating must be laid and operated across the full area of the room. Partial underfloor heating is not permitted. A temperature of 27°C on the surface adjacent to the underside of the flooring should not be exceeded at any time anywhere over the area. Any complaints in connection with the operation or the installation of a floor heating system is excluded if the requirements described above are not met. Claims can be asserted solely within the scope of our general warranty and guarantee provisions. For underfloors with or without underfloor heating, the specialist installer must perform and record the necessary CM measurement prior to installing the floor. The following limit values apply to residual humidity:

with cement screed	< 1.8% CM with underfloor heating
with calcium sulfate screed	< 0.3% CM with underfloor heating

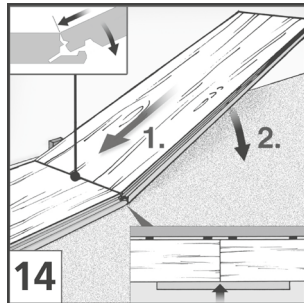
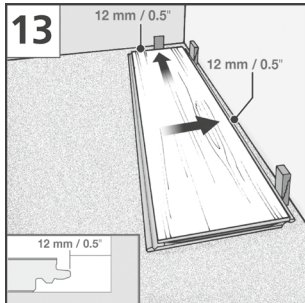

For floating installation, the thermal resistance of the laminate floor and the insulating substrate must be observed. The total of the thermal resistance of all components must be $\leq 0.15 \text{ m}^2 \text{ K/W}$ in accordance with the requirements of DIN EN 14041. When using the insulating materials which do not come as part of the range of accessories, any warranty is excluded in the case of floating installation on heating screeds with regard to compliance with the effective maximum permissible thermal resistance of the overall construction.

It is recommended that the panels be sorted according to the desired pattern lines and (if necessary) colour nuances prior to installation. You should start working with packages of laminate flooring immediately after opening!

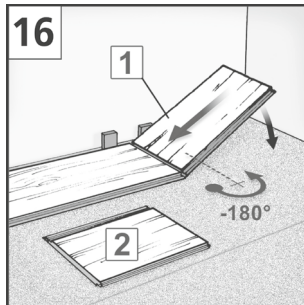
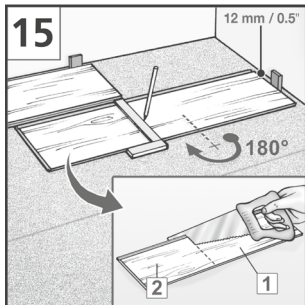

Installation: It is recommended that you lay out the panels in the direction of the length and the source of light [12].

For unusual wall angles, you must first transfer the profile of the wall-line to the first row of panels and saw the panels accordingly. Measure the spatial dimensions of the room prior to installation. In the event that the first row of panels proves to have a width of less than 5 cm / 2", you must then evenly partition the remaining length (excess length) among the first and last row of panels in such a manner that both rows are cut to size with the same (symmetrical) panel-width.

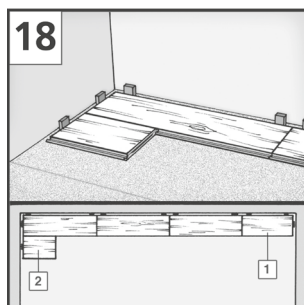
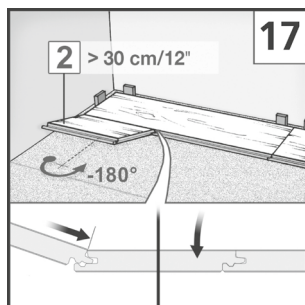

For secure transverse joint locking the hammer and hammering block must be used [20].

Begin your installation in the left corner of the room. Lay out the first panels with the tongue-spring side facing the wall and secure the edge separation (gap) with shims. It is important to retain a 12-15 mm / 0.5"-0.6" edge distance (expansion gap) from the wall, heating pipes, posts, doorstop, etc. [13].

Insert a second panel with the facing edge (short side) at an angle of 30° into the groove profile of the previously laid panel [14] and then lay flat on the floor. Make sure that the longitudinal edges are aligned. Ensure that they are not offset and form a straight line. This is necessary to insert the panels with-out gaps into the longitudinal profile when laying the second row of panels.

Click in further panels until the end of the first row in the same manner.

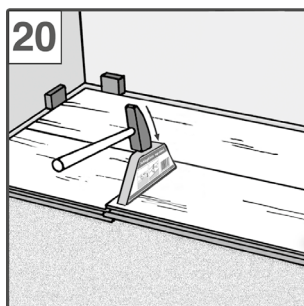
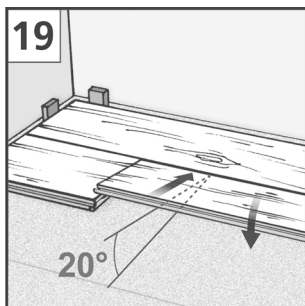

Turn the last panel in the row [15] by 180° for adjustment / trimming; place the decorated side up next to the existing row (groove cheek to groove cheek) on the right side of the wall. Take an edge distance of 12-15 mm / 0.5"-0.6" on the facing side into account. Mark and cut the panel lengths. The last panel of the 1st row is also inserted at an angle of 30° into the groove profile of the previously laid first panel and then laid. Make sure that the longitudinal edges are aligned. Ensure that they are not offset and form a straight line.

In order to avoid splintering of the edges, the decorated side should face down when using electrical jigsaws or hand-held circular saws. Otherwise, cut down from the top of the panel. Begin each new row with the remnants (at least 30 cm / 12" in length) of the previous row.

Begin the second row with a half panel (length < 95 cm / 37.40") or with a remnant panel (length < 30 cm / 12") [17, 18]. Insert the panel section length-wise in the groove profiling in the first row and lock it in place / bend it [19]. The transverse joint must be offset by at least 30 cm / 12" from row to row.

Place a second panel length-wise in the groove profiling of the panel area and push it to the left at an angle of 20° to the panel already in place [19]. Then push it downwards and press from above using the hammer and the hammering block until you hear an audible click [19, 20, 21]. In doing so, ensure that the panel is inserted and guided cleanly through the longitudinal profile. If no system-related insulation underlay has been used, use a hammering block and a hammer [20] to lock the two panels.

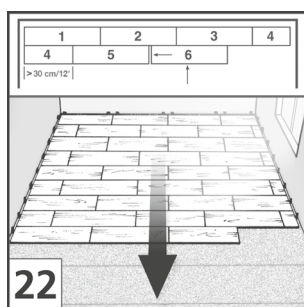
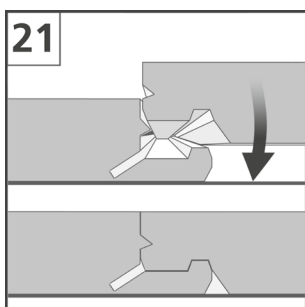

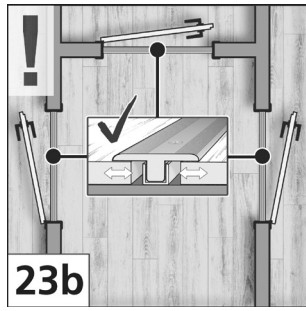
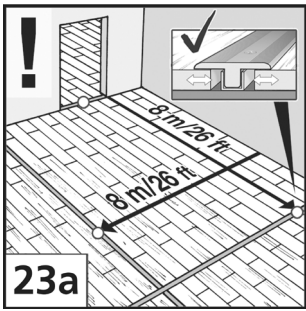

For installation surfaces with more than 8 metres / 26 ft length or width, and for considerably angled rooms, expansion joints (at least 2 cm / 0.8" wide) are necessary [23a]. This allows the floor to respectively expand or contract during climatic changes. Keep this in mind when installing flooring through one room to another. In this case, the surfaces in the area of the door frame must be interrupted [23b]. Expansion joints can be properly masked with corresponding profiles. The movement gaps may not be filled with cables or other materials. Please observe the requirements of the ATV DIN 18365. The floor screed joints from the ground need to be adopted. The design of the movement joints must allow for the same movement options.

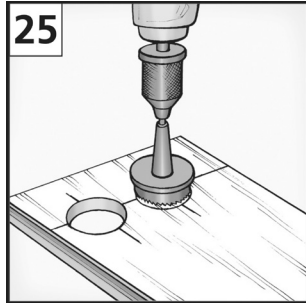
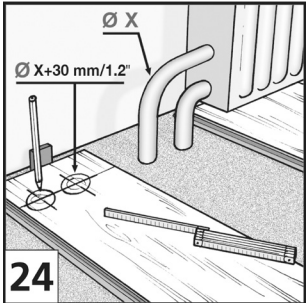

For heating-radiator pipes, holes that are drilled 3 cm / 1.2" larger than the pipe diameter must be avoided. A "fitting piece" should be cut out, glued, fitted in and fixed in place with a wedge until the glue has dried. Then cover the recesses with a radiator-sleeve [24 - 27].

Wooden doorframes should be shortened enough that a panel with footfall sound insulation including 2-3 mm / 0.8"-1.2" gap can fit underneath [28, 29].

After installation, remove the separation wedges.

Then, for a perfect completion of your project, attach the baseboard cleats in intervals of 40-50 cm / 16"-20" onto the wall and put the respectively cut baseboard in place [32].

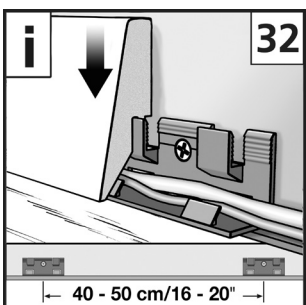
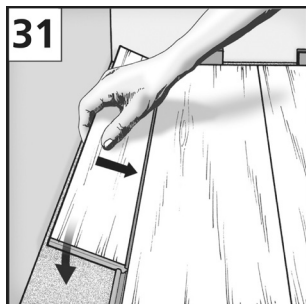
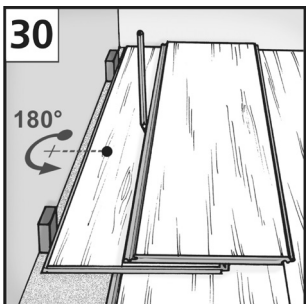
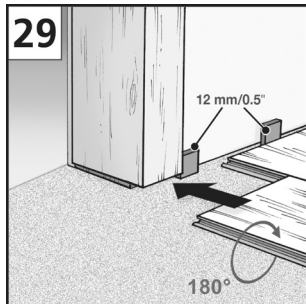
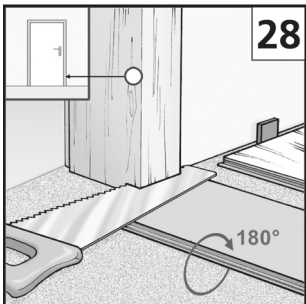
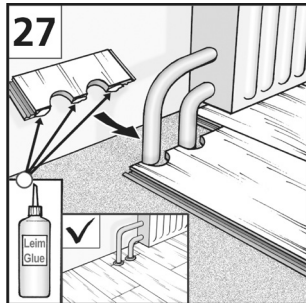
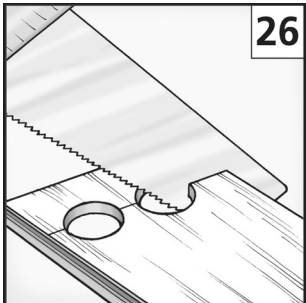

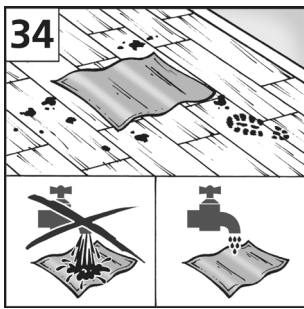

Cleaning and Maintenance

Remove dirt by sweeping or with a vacuum suitable for hard floors [33].

For general maintenance, use only the wiping materials recommended by the manufacturer of the laminate. The following are not suitable for the treatment of laminate flooring surfaces: polish and cleanser with treatment additives such as wax or oil. The laminate flooring should not be polished [33].

Wipe up foot-prints and dirt with a thoroughly-squeezed and drip-free cloth. Standing water should be avoided in all circumstances [34]!

Special care should be taken regarding flower pots, vases, etc. that are standing on the laminate. Use a water-proof support underneath the object.

Stubborn spots should be selectively cleaned and removed with a suitable cleanser spray or acetone. Do not apply additional sealant onto the laminate flooring surface.

Attention! Protect the flooring from scratches or indentations! Use a sufficiently large doormat around the entry areas.

Furniture feet made of wood, metal or plastic must be furnished with felt-protectors. Office chairs with soft rollers (DIN 12529) are only to be used [35], or lay down a commercial quality protective matt. With consideration of these instructions, you will extend the longevity of your laminate flooring and be able to retain complete claim to the guarantee particulars.

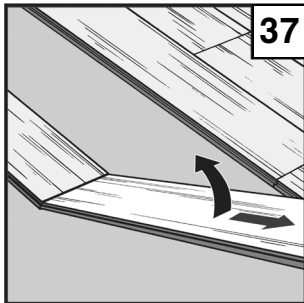
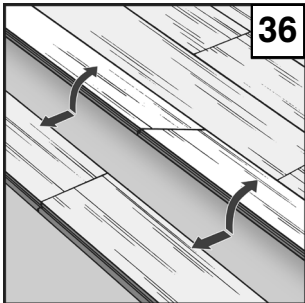
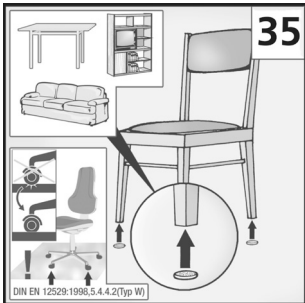

Lifting or removing

It is possible to replace or remove panels that have been laid as floating flooring in living areas and commercial areas without causing damage by first releasing the whole row along the long side by angling it to free it from the locking mechanism [36]. Next, the panels, while lying flat on the floor on the head side, should be bent on the narrow side and released from the bonding [37]. Please be particularly diligent and careful when undertaking this work in order to avoid damaging the tongue-and-groove sections.